



**ZANTIA**<sup>®</sup>

Inspired by *Comfort!*

# Instruction Manual

**DOMESTIC GAS INSTANTANEOUS WATER HEATER**

**LYON 11L**



# Content

Outline .....	3
1 User Instructions .....	4
2 Usage .....	5
3 Installation Instruction .....	7
4 Connection to water, gas and pipe .....	8
5 Gas Conversion Instruction .....	10
6 First Use .....	11
7 Maintenance .....	11
8 Technical Data .....	12
9 Malfunction and Remedies .....	15

## Outline



It is very necessary to read through all the warnings and contents in this manual before installation.

- Please read carefully this manual before installation.
- **The installation, connection and first use of this gas water heater must be carried out by technician personnel. Incorrect installation or maintenance might cause risk to health or death.**
- Please read carefully this manual before ignition.
- The water heater must be installed in a well-ventilated place outside the bathroom.
- It is forbidden to interfere with sealed components.

### **Factory declaration:**

ZANTIA Gas Instantaneous water heater is in conformity with the following EC directive:

- Gas Appliance Directive (2009/142/EC)
- EMC Directive (2004/108/EC)

and that the following harmonised standards have been applied:

- relevant harmonised gas appliance standards
- EN 26 1997+A1:2000+A2:2004+A3:2006
- EN 55014-1: 2006 +A1:2009 +A2:2011

### **Packing List**

- 1 x gas instantaneous water heater
- 1 x Instruction Manual
- 1 x Installation bracket
- 2 x Screws and plastic plug

# 1 User Instructions



This product can only be used under the purpose described in this manual, that is, to provide heated water for domestic use.



This product can only be used under normal operation conditions.



In case of any malfunction or failure, please contact with maintenance personnel.



Do not damage lead sealing labels or other labels.



Improper use might cause accidents.



Never cover the exhaust vent.



When in operation, the surface of water heater might reach 40 K, watch the burn!



Please keep this manual in a place near the product and within reach.

## Prevention of gas accidents:

If gas leakage is found, you shall

1. Immediately shut off the gas water heater.
2. Shut off the gas switch.
3. Prohibit of open fire or any spark.
4. Open all the windows and doors.
5. To contact with the installation personnel and local gas supply company.

- This product can only be used with gas type and gas pressure described in the technical plate.
- Gas conversion of gas water heater must be carried out by professional technician personnel and must use companion spare parts.
- The pipe connectors shall be checked with soap-suds at regular interval to see if there is gas leakage.
- If the gas connector is connected with rubber hose, please replace it once a year. And the hose should be certified to applicable EN standards and local codes.
- If the flame is abnormal when using natural gas, please contact with local gas supply company.
- check that the information of Technical Data concerning the state of adjustment given on the data plate or the additional plate shall be compatible with the local supply conditions

## Prevention of fire accident

- Never leave the house or go to bed when the water heater keeps heating water.
- Never put inflammable and explosive goods near the water heater.

### Prevention of poisoning:

- When water heater is in use, oxygen inside the room where it is installed will be consumed, so please keep the room well ventilated.
- Please read carefully the manual and obey instructions of the installation personnel to prevent any poisoning accident.
- A ducting pipe must be installed and in a correct way, if necessary, please ask the help of installation personnel.
- For natural gas water heater, if the flame color turns from blue to yellow, it means gas pressure is too low, please contact with installation personnel and local gas supply company.

### Maintenance

- To check and clean water heater every six months.
- To observe flame regularly, if flame turns from blue to yellow and accompanied with black smoke, then the water heater must be cleaned.

## 2 Usage

### 2.1 Ignition

The water heater will automatically ignite when the outlet water valve is opened. If there is only noise but without flame, immediately shut off the outlet water valve and wait 10 seconds then reignite.

Notice: if the water heater is not used for a long time, then above operations shall be carried out for many times so to exhaust out all the air inside the pipe then the water heater can be successful ignited.

### 2.2 Adjustment of Heat Output

Gas flow can be controlled by adjusting the gas knob, and in this way heat output of gas water heater can be changed. You can adjust the heat output by adjusting the gas knob between maximum and minimum flame.

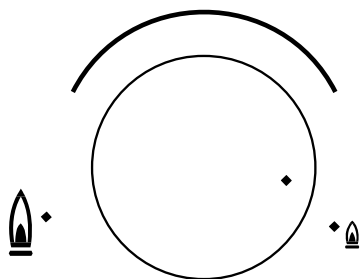

Minimum flame 

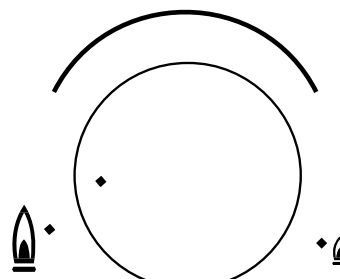

Maximum flame 

## 2.3 Adjustment of water temperature

Water flow can be controlled by adjusting water temperature knob, and in this way outlet hot water temperature can be changed. You can turn the water temperature knob clockwise to decrease outlet hot water temperature and turn the knob anti-clockwise to increase hot water temperature.

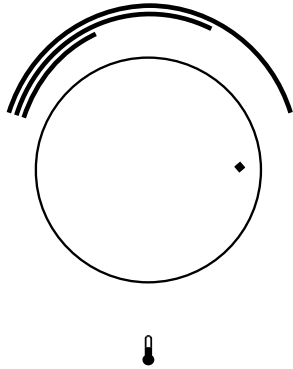

Low water temperature

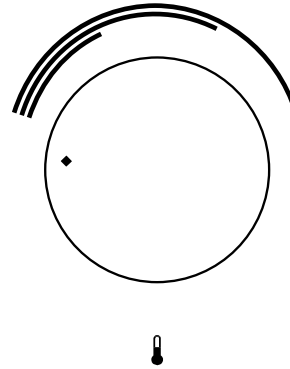

High water temperature



**The check valve on cold water supply line must be totally opened, and never control water flow by adjusting check valve.**

## 2.4 Anti-freezing

If you plan not to use the water heater some period of time, then please use the methods below to drain off water inside the water heater.

1. Shut off gas valve.
2. Take out batteries.
3. Shut off the check valve on cold water supply line.
4. Turn the water temperature knob to minimum temperature position.
5. Open hot water valve.
6. Open drainage valve to drain off the water inside.
7. Shut off the drainage valve.

## 2.5 Flame failure

If the flame suddenly stops burning when the water heater is in operation, it might be because of the thermostat functions. At this time, the system will automatically cut off and stop supplying gas. Only when the water heater cools down then you can reignite it.

1. To make sure the flue is not blocked up.
2. Wait till the water heater cools down.
3. Shut off water tap and then open it again.

If the water heater fails to operate, please refer to table of "Malfunction and Remedies". If malfunction occurs again, please contact with maintenance personnel.

### 3 Installation Instruction

- 3.1** The product is assembled with a flue thermostat (combustion products discharge safety device), if flue is blocked up, the thermostat will function, then gas valve will be shut off and the water heater cannot be ignited before it cools down. Never put this thermostat out of operating. It will be serious to timely interfere with the thermostat. Only Powtek's original parts shall be used if you need to replace the defective parts. Technical personnel need to block up the flue to check whether or not the water heater can be shut off after replacement of the thermostat. If shut off, it proves that the thermostat function is ok. It will be necessary to take appropriate action to remedy the thermostat in the case of repeated shutdown of the water heater. The thermostat will be reset when the temperature is lower than 50°C. The thermostat will interrupt the admission of gas to the burner if the evacuation of the combustion products is disturbed, then close the water valve and wait 5 min until the appliance cool down. Then operate the appliance as normal. If there are repeated interruptions, please call a specialist



**Never damage the flue gas controlling system.**



**The damage of the flue gas controlling system might cause harm to health or even death.**

### 3.2 Installation Method

- The wall on which the water heater is mounted should be strong enough to withstand the weight of the device. And the wall should not be sensitive to heat. If it is wood, some suitable insulation protected should be took.

- This gas water heater can only be installed in a well-ventilated place outside bathroom.
- Must ensure well ventilation inside the room where gas water heater is installed.

- Do not install in a room below 0°C .
- Do not install in a damp room.

- The room where gas water heater is installed shall have a volume larger than 7.5 m<sup>3</sup>. The sum of the room volume and the oxygen volume the gas water heater will consume shall be larger than 17 m<sup>3</sup>.

- The room shall be well ventilated and shall have air inlet holes with area larger than 0.06m<sup>2</sup>. The air inlet holes shall be near the ground and connected with outdoor so to ensure the air of outdoor can goes inside the room.

- There shall not be any visible wires, electrical equipments or gas pipeline above the gas water heater.

- There shall not be any gas oven, gas stove or other gas appliances under the gas water heater.

- For easy maintenance and cleaning, there shall be at least gaps (a) of 100 mm at two sides and a gap (b) of 300 mm below the water heater.

- The pipe to the roof and walls around shall have a distance (d) of longer than 550 mm.

- No combustible goods shall be kept within 500 mm of the water heater.

- The water heater shall be hung and installed in a vertical way.

- The water heater shall only be installed outside or in a room which is separated from inhabited rooms and supplied with appropriate ventilation directly to the outside.

- This appliance may only be installed in a room if the room meets the appropriate ventilation requirements

- This appliance shall be installed in a suitably ventiated room, in accordance with the regulations in force.

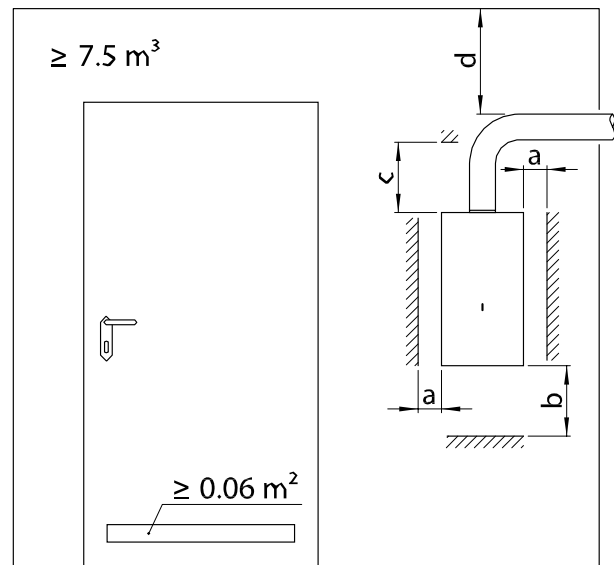

Use methods as below to install the water heater:

1. Use installation template of the graph in “Technical Information” to decide positions of installation holes.
2. If necessary, use installation template to pre-install connection parts of gas, flue gas and water pipe.
3. Open the flip cover and shut off controlling knobs.
4. Unscrew the two screws on the bottom of the framework and dismantle the framework.
5. Install the water heater.
6. Take off the plastic cap from the connectors.
7. Install connectors. (Refer to the part of “Connection to Water, Gas and Pipe”)
8. Install framework and put on controlling knobs.

## 4 Connection to Water, Gas and Pipe



**Gas water heater connections can only be carried out by professional technician personnel.**



**Obey national installation rules.**



**Make sure that the gas and gas pressure are same as those described on the gas water heater technical plate.**



**Please carefully clean dirt and installation residues before connecting gas pipe and water pipe to the water heater.**

### 4.1 Connection to Gas

- Gas supply pipe shall be installed with a companion gas valve of G1/2” (as reference image below).
- If necessary, a pressure-relief valve must be installed on gas supply line.

### 4.2 Connection to water

- A check valve must be installed on cold water supply line (as reference image).
- We suggest install a pressure-relief valve on cold water supply line.
- Connect a check valve to cold water pipe.
- Use a corrugated hose to connect cold water inlet and check valve.
- Use another corrugated hose to connect hot water outlet to water tap.

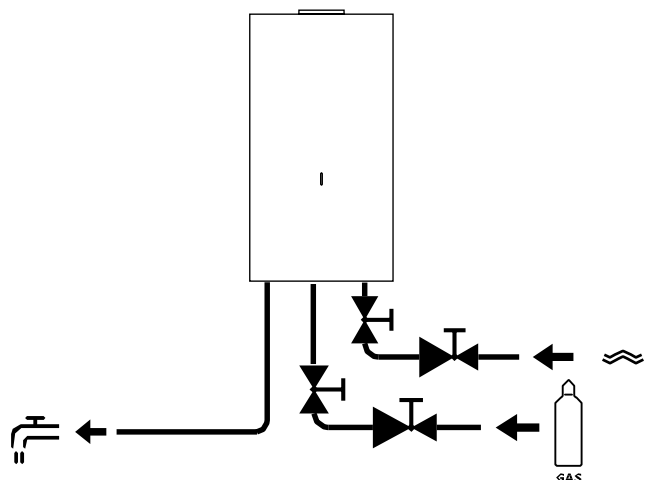



### 4.3 Connection to Flue



**This product must be connected to flue or a chimney.**

This product must be connected to specially designed flue before use. The flue shall meet the specifications as below:

- Minimum vertical length: 0.5 m.
- Maximum length: 3 m.
- Maximum turns: 2 x 90°, one elbow pipe shall be connected with a straight pipe of 1 m.
- A wind cap must be installed on the end of the pipe or the chimney.
- The distance (g) between the wind cap and wall shall be at least 150mm.
- The parts of pipe must be fixed firmly.
- The pipe mustn't be installed through the ceiling.
- Do not install the pipe through combustible goods; for unavoidable circumstances, the combustible goods must be wrapped by insulating materials of no less than 20 mm thickness.
- The gap of the hole between the pipe and the wall mustn't be stuffed with cement or similar material, so that it is convenient for maintenance.
- There shall be an air inlet near the ground in the installation room.

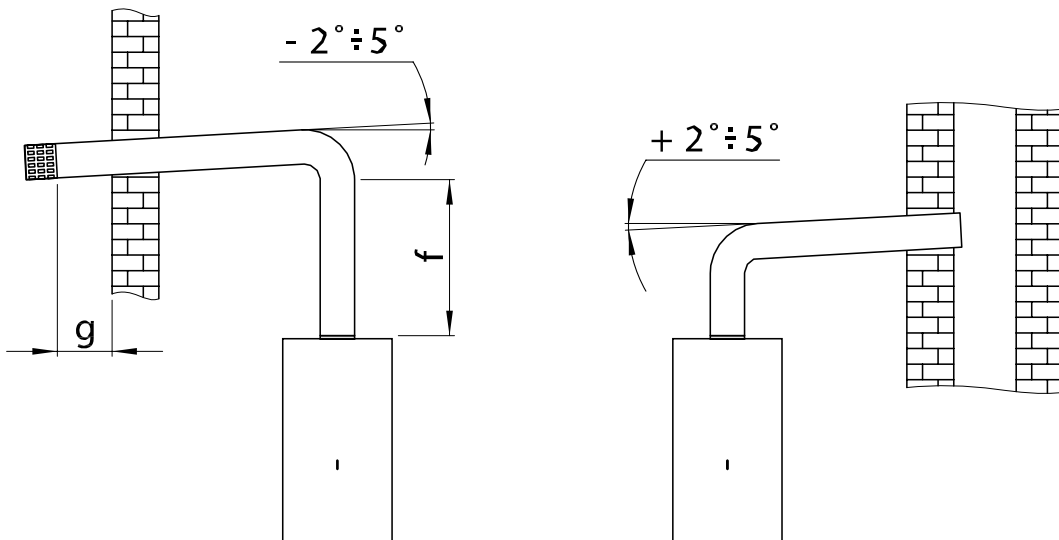

Pipe installed through the wall

Pipe installed through chimney

## 5 Gas Conversion



Different gas conversion of gas water heater must be carried out by professional technician personnel.

Any broken seals shall be re-made and/ or any adjuster shall be sealed.

A self-adhesive label which is intended to be fitted on the water heater shall be supplied with the parts and the conversion instructions provided by ZANTIA. The supplementary marking indicating the appliance conversion shall be stated on the label.

### 5.1 Gas conversion instruction

(1): Gas manifold must be changed in order to converse to different gas type

1. - Dismantle gas manifold from the valve;
2. - Dismantle gas manifold from the burner;
3. - Replace the manifold (check the label on it); please refer to the graph "Nozzle specification" shown in "Technical Data", and use new O rubber seals.
4. - Check if the connecting parts of the gas manifold are fixed firmly.
5. - After conversion and before first use, please refer to "Nozzle specification" shown in "Technical Data" for rated pressure.

## 6 First Use



The first-time use of water heater shall be carried out by professional technician personnel.

- Open battery box and put two batteries (model. LR20, 1.5V) inside.
- Open hot water valve to let water run out and then shut off it.
- Open gas inlet valve.
- Turn the heat output knob (gas knob) to maximum position.
- Open hot water outlet valve.
- Observe the flame.
- For first-time use, please refer to “Nozzle specification” shown in “Technical Data” for rated pressure.

## 7 Maintenance



Maintenance of gas water heater shall be carried out by professional technician personnel.



Obey national maintenance rules.



Before carrying out maintenance, the water heater shall be cooled down.



Must use specific spare parts supplied by ZANTIA, otherwise, we do not accept any claims.

### 7.1 Connection to Gas

- For LPG gas water heater: if using rubber hose to connect to gas circuit, please replace the rubber hose every year.
- Use soap-suds to check gas connectors to see if there is any leakage.

### 7.2 Heat Exchanger

- Shut off gas inlet valve.
- Dismantle the end cap of gas water heater.
- Shut off water inlet valve.
- Open hot water outlet valve.
- Open drainage valve to release the water.
- Disassemble heat exchanger from the water heater.
- Use a paint brush to clean the fins of the heat exchanger.
- Use water spouts to clean heavy dirt.

### 7.3 Burner

- Dismantle the burner off the water heater.
- Use a paint brush to clean its surface and top, and blow away the dust on the burner fins.

## 7.4 Water Inlet Filter

- Dismantle water pipe from cold water inlet of the water heater.
- Take off and clean the cold water inlet filter.

## 7.5 Framework

- Use soft cloth with neutral detergent to clean the framework. DO NOT use chemical or corrosive detergent to clean.

## 8 Technical Data

		<b>LYON 11L</b>	
Pin code	n°	598 CO 402	
Type		B11BS	

Heat input (Hi)	Q <sub>n</sub> (Hi)	kW	22.0
Min. Heat input (Hi)	Q <sub>min</sub> .(Hi)	kW	13.0
Heat output	P	kW	19.0

### Heat efficiency

Nominal heat efficiency	%	>84
-------------------------	---	-----

### Gas data

Gas categories	<input type="checkbox"/> II2E+3+	<input type="checkbox"/> II2H3+	<input type="checkbox"/> II2H3B/P	<input type="checkbox"/> II2E3B/P	<input type="checkbox"/> II2E3P	<input type="checkbox"/> I3B/P(30)
Gas type	<input type="checkbox"/> G20 <input type="checkbox"/> G30/31	<input type="checkbox"/> G20 <input type="checkbox"/> G30/31	<input type="checkbox"/> G20 <input type="checkbox"/> G30,G31 or their mixtures	<input type="checkbox"/> G20 <input type="checkbox"/> G30,G31 or their mixtures	<input type="checkbox"/> G20 <input type="checkbox"/> G31	<input type="checkbox"/> G30,G31 or their mixtures
Gas pressure (mbar)	<input type="checkbox"/> 20 <input type="checkbox"/> 28~30/37	<input type="checkbox"/> 20 <input type="checkbox"/> 28~30/37	<input type="checkbox"/> 20 <input type="checkbox"/> 28~30	<input type="checkbox"/> 20 <input type="checkbox"/> 28~30	<input type="checkbox"/> 20 <input type="checkbox"/> 37	28~30
Destination countries	BE,FR	CH,ES,GB GR,IE,IT PT	CZ,DK,EE,FI HU,IS,LT,LV NL,NO,SE,SI SK,BG,RO,TR	LU	PL	CY,MT



### Gas consumption

N.G. consumption – G20	m <sup>3</sup> /h	0.82~2.25
L.P.G. consumption – G30	kg/h	0.58~1.35

### Flue gas data (15 °C, 1013.25 mbar, dry flue gas)

Flue gas nominal flow rate	g/s	6.4
Flue gas mean temperature	°C	170

### Hot water data

Nominal water flow rate	D	ltrs/min	11
Cold inlet water is 15°C, water temperature of maximum flame can reach 1) 		°C	40 - 85
Cold inlet water is 15°C, water temperature of minimum flame can reach 1) 		°C	22 – 33
Minimum water pressure		bar	0.5
Maximum water pressure	pmw	bar	10

### Electricity data

DC Battery		2xDC 1.5V
------------	--	-----------

### Connectors' data

Water pipe connector		inch	½"
Gas pipe connector		inch	½"
Flue diameter		mm	110
Flue length	min. / max.	m	0.5 - 4

### Dimension / Weight

Width x Height x Depth	mm	310 x 580 x 230
Weight	kg	10.2

Liquefied Petroleum Gas: ( )

1) Inlet cold water temperature: 15 °C

### Nozzle specification

		<b>LYON 11L</b>	
Nozzles quantity	–	12	

### Natural gas G20

Nozzle diameter	mm	1.07
Nozzle rated pressure	mbar	20

### Liquefied Petroleum Gas G30/G31

Nozzle diameter	mm	0.70
Nozzle rated pressure	mbar	28-30/37

## 8.1 Dimensions

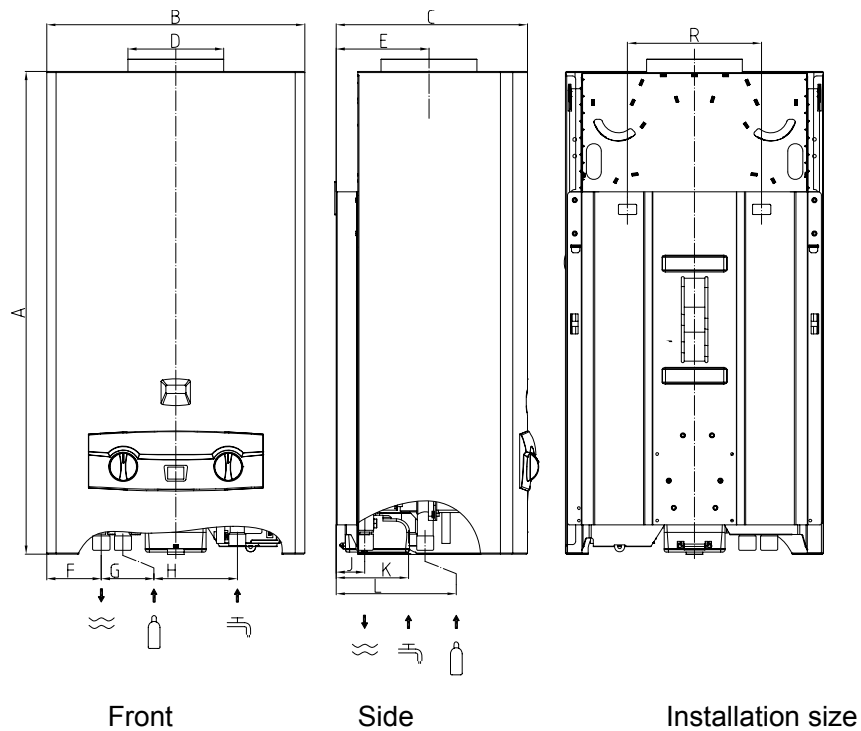

		<b>LYON 11L</b>	
<b>Gas water heater dimensions</b>			
A	mm	580	
B	mm	310	
C	mm	230	
<b>Connectors Sizes</b>			
D	mm	115	
E	mm	111	
F	mm	65.5	
G	mm	26	
H	mm	137	
J	mm	34	
K	mm	87	
L	mm	107	
<b>Installation size</b>			
R	mm	161	

## 8.2 LYON 11L internal structure drawing

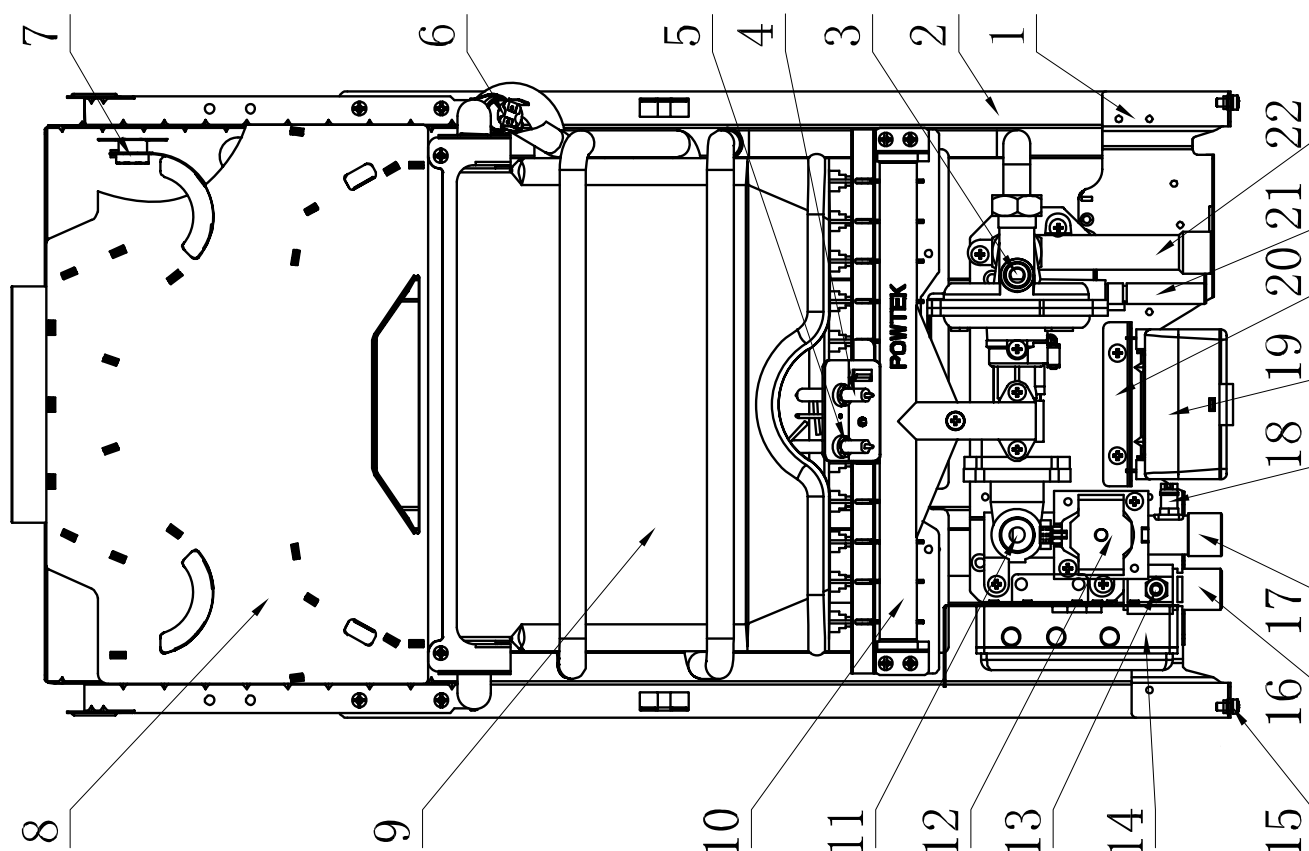

- |    |                           |    |                         |
|----|---------------------------|----|-------------------------|
| 1  | Valve bracket             | 12 | Electromagnetic valve   |
| 2  | Back panel assembly       | 13 | Temperature sensor      |
| 3  | Water valve core assembly | 14 | Pulse ignition (PCB)    |
| 4  | Flame sensing electrode   | 15 | Screw (M5X8)            |
| 5  | Ignition electrode        | 16 | Water outlet            |
| 6  | Hot water thermostat      | 17 | Gas valve               |
| 7  | Flue gas thermostat       | 18 | Gas pressure test point |
| 8  | Draft hood                | 19 | Battery box             |
| 9  | Heat exchanger            | 20 | Battery box heat shield |
| 10 | Gas manifold assembly     | 21 | Safety valve            |
| 11 | Gas valve core assembly   | 22 | Water inlet             |

## 9 Malfunction and remedies



Severe harm or death might be caused if the following instructions are not followed.



In case of malfunction, please shut off the water heater immediately and contact with technician personnel.



**MUSTN'T** try to repair the water heater by yourself.



**MUSTN'T** use the water heater if it appears malfunction.



Must use specific spare parts supplied by ZANTIA, otherwise, we do not accept any claims.

### 9.1 Malfunction Sheet

Causes \ Malfunctions	Fire goes out during use	No ignite after turning on	The flame bursts	Flame is yellow	Abnormal flame with peculiar smell	Difficult ignition	Outlet water temperature is too low	Outlet water temperature is too high	Fire doesn't ignite at low temp.	Fire isn't out after water heater is off.	Remedies
Flue is blocked up.	●										Check the flue and make sure it is not blocked up.
Gas valve is not open.		●									Fully open gas valve or replace gas tank.
Gas valve is half open.							●				Fully open gas valve
There is air inside gas valve.		●									Repeatedly turn on and off the outlet water valve until the water heater ignites successfully.
Gas pressure is too high.			●			●		●			Contact with maintenance personnel
Gas pressure is too low.	●						●				Contact with maintenance personnel
Freezing		●									Contact with maintenance personnel
Inlet water pressure is not enough.	●	●						●	●		Contact with maintenance personnel
Burner is blocked.				●	●	●					Contact with maintenance personnel
Heat exchanger is blocked.	●			●	●						Contact with maintenance personnel
Water controlling device defect	●	●					●	●		●	Contact with maintenance personnel
Pulse ignition defect	●	●									Contact with maintenance personnel
Internal wires looses	●	●									Contact with maintenance personnel
Micro-switch defect		●									Contact with maintenance personnel
Batteries are put at wrong terminals		●									Put the batteries correctly
Electromagnetic valve defect	●	●									Contact with maintenance personnel
Feedback electrode defect	●										Contact with maintenance personnel
Discharge distance or part is abnormal.			●								Contact with maintenance personnel
Batteries have run down.	●	●									Replace with new batteries
Inlet water valve is not opened.		●									Fully open inlet water valve
Fresh air is not enough.				●	●	●					Contact with maintenance personnel

Inspired by *Comfort!*

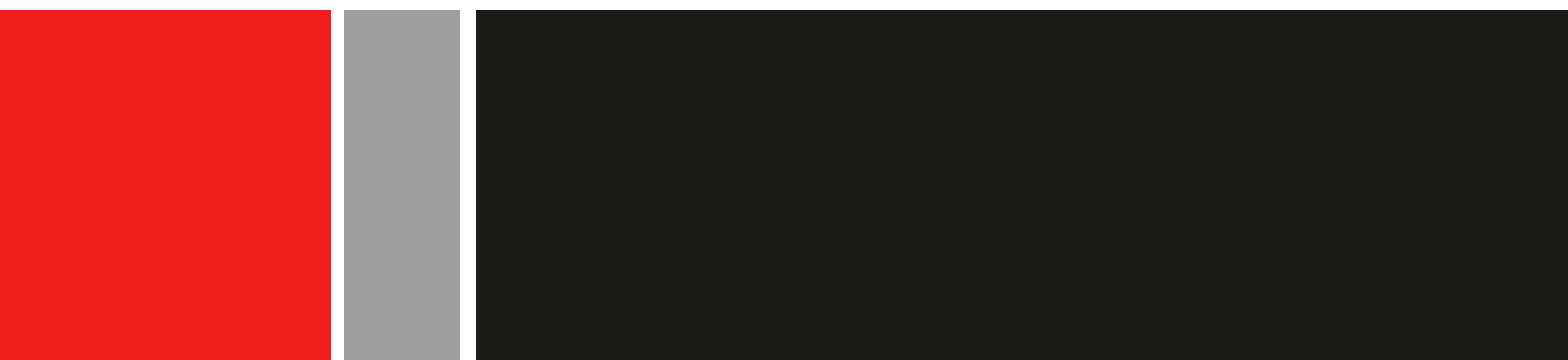

[www.zantia.com](http://www.zantia.com)