



## Lithium-Ion Storage Battery





## 1. SAFETY PRECAUTIONS



### 1.1 Reminding

- 1) It is very important and necessary to read the user manual carefully (in the accessories) before installing or using battery.
- 2) If the battery is stored for long time, it is required to charge them every six months, and the SOC should be no less than 80%;
- 3) Battery needs to be recharged within 12 hours, after fully discharged;
- 4) Do not expose the battery over 60°C and cable outside;
- 5) All the battery terminals must be disconnected when maintenance;
- 6) Please contact the supplier within 24 hours if there is something abnormal.
- 7) Do not allow the battery to contact with liquid;
- 8) Do not expose battery to flammable or harsh chemicals or vapors;
- 9) Do not disassemble the battery;
- 10) Do not connect battery with PV solar wiring directly;
- 11) The warranty claims are excluded for direct or indirect damage due to items above.
- 12) Any object is prohibited to insert into any part of battery.



### 1.2 Before Connecting

- 1) After unpacking, please check product and packing list first, if product is damaged or lack of parts, please contact with the local retailer;
- 2) Before installation, be sure to cut off the grid power and make sure the battery is in the turn-off mode;
- 3) Positive and negative cables must be re-confirmed, and ensure no short circuit with the external device;
- 4) It is prohibited to connect the battery and AC power directly;
- 5) The embedded BMS in the battery is designed for 48VDC, please do not connect battery in series;
- 6) Please ensured the electrical parameters of battery system are compatible to related equipment;
- 7) Keep the battery away from liquid and fire.

### 1.3 In Using

- 1) If the battery system needs to be moved or repaired, the power must be cut off and the battery is completely shutdown;
- 2) It is prohibited to connect the battery with different type of battery.
- 3) It is prohibited to put the batteries working with faulty or incompatible inverter;
- 4) It is prohibited to disassemble the battery (product tab removed or damaged);
- 5) In case of fire, only dry powder fire extinguisher can be used, liquid fire extinguishers are prohibited;
- 6) Please do not open, repair or disassemble the battery except staffs from ZANTIA or authorized by SOFAR. We do not undertake



any consequences or related responsibility which because of violation of safety operation or violating of design, production and equipment safety standards.

## 2. SPECIFICATIONS

### 2.1 Basic parameters

Basic Parameters	Specifications
Total Energy	2400Wh
Usable Energy	2000Wh
Nominal Voltage	48.0V
Weight	29Kg
Dimension	95mm*450mm*640mm
Depth Of Discharge (DOD)	80%
Cycle Life (80%DOD)	>6000,25°C
Design Life	10+ Years(25°C/77° F)
Discharge Voltage	45V ~ 54.0V
Charge Voltage	51.8V ~ 54.0V
Cont. Charge Current	25A
Max. Charge Current	25A
Cont. Discharge Current	50A
Max. Discharge Current	65A
Communication Port	CANbus + RS485
Operating Temperature	-20~+60°C
Storage Temperature	5°C ~ +45°C
Scalable	Up to 4 units
Installation method	Wall-mounted
Certificates	CE / IEC62619 / RCM / SAA

52.5



## 2.2 Dimension

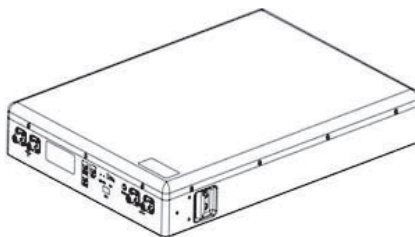
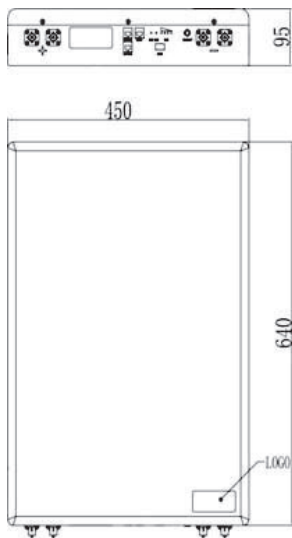

## 3. Equipment Interface Instruction

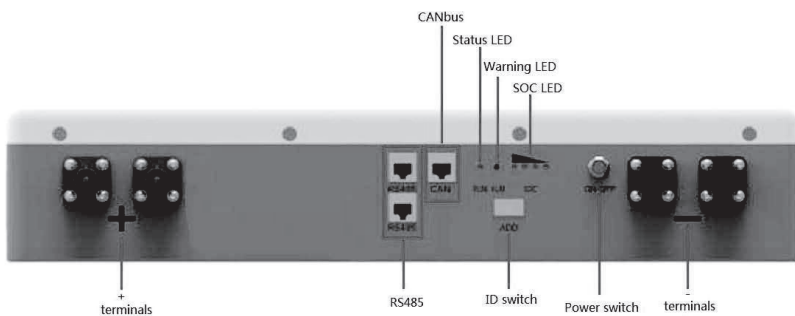

Power switch(ON/OFF)	To turn ON/OFF the whole battery PACK standby, no power output.
Status LED(RUN)	Green LED flashing to indicate the battery operation status.
Warning LED(ALM)	Red LED flashing to indicate the alarm of battery and battery is at protection mode.
SOC LED(SOC)	Green LEDs to indicate the battery capacity.
Terminals +/-	There are two pair of terminals with same function, one connects to equipment, the other one paralleling to other battery module for capacity extension. For each single module, each terminal can achieve charging and discharging function.
CANbus(CAN)	Follow CAN protocol (RJ45 port) to transfer battery information for storage inverter.
RS485	Follow RS485 protocol, communicate link between battery in parallel.
ID switch(ADD)	6 ADD switches, Dip1~3 to define Master/Slave mode, Dip4~6 to define slave battery.

### 3.1 SOC LED(SOC)

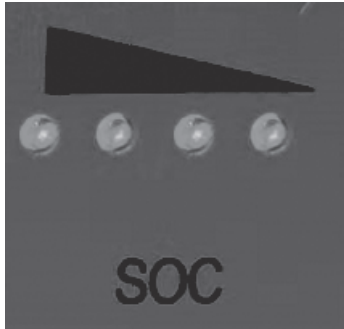

SOC	LED			
	●	●	●	●
	LED4	LED3	LED2	LED1
0~25%	OFF	OFF	OFF	ON
25~50%	OFF	OFF	ON	ON
50~75%	OFF	ON	ON	ON
75~100%	ON	ON	ON	ON

### 3.2 ID switch(ADD)

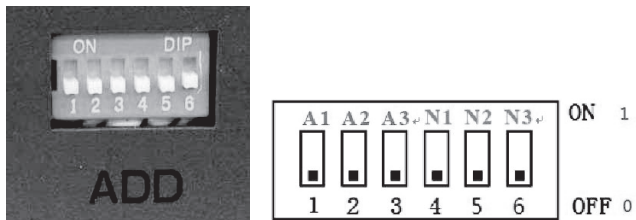

ADD	A1	A2	A3
Master	0	0	0
Slave 1	1	0	0
Slave 2	0	1	0
Slave 3	1	1	0
Slave 4	0	0	1
Slave 5	1	0	1
Slave 6	0	1	1
Slave 7	1	1	1

ADD	N1	N2	N3
Slave Qty*0	0	0	0
Slave Qty*1	1	0	0
Slave Qty*2	0	1	0
Slave Qty*3	1	1	0
Slave Qty*4	0	0	1
Slave Qty*5	1	0	1
Slave Qty*6	0	1	1
Slave Qty*7	1	1	1

- Counting mode of ID switch is binary. A1/A2/A3 mean ID code and N1/N2/N3 mean the quantity of slave battery. When the button is at “ON”, it is defined “1”. So “OFF” is defined “0”.
- Only master battery can communicate with storage inverter in CANbus.

### 3.2.1 ID switch(ADD) - 10kwh battery connection

- For example, if there are four batteries in parallel.
  - First battery connection with storage inverter, we called it is master battery and the others are slave batteries.

ID code of master battery is “A1~A3=0, N1=1, N2=1, N3=0”as below table list.

ADD	A1	A2	A3
Master	0	0	0

ADD	N1	N2	N3
Slave Qty*3	1	1	0

- Slave 1 battery is “A1=1, A2=0, A3=0, N1~N3 same as master battery”.

ADD	A1	A2	A3
Slave 1	1	0	0

ADD	N1	N2	N3
Slave Qty*3	1	1	0

- Slave 2 battery is “A1=0,A2=1,A3=0, N1~N3 same as master battery”.

ADD	A1	A2	A3
Slave 2	0	1	0

ADD	N1	N2	N3
Slave Qty*3	1	1	0

- Slave 3 battery is "A1=1,A2=1,A3=0, N1~N3 same as master battery".

ADD	A1	A2	A3
Slave 3	1	1	0



ADD	N1	N2	N3
Slave Qty*3	1	1	0

## 4. Installation



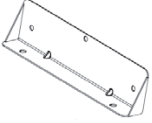

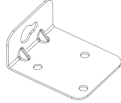
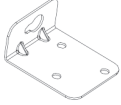

 <b>Warning</b>	<p>Stop the battery operation immediately to secure the battery safety when environmental temperature is over working temperature (suitable operation temperature is 0~45°C). If battery is at high temperature usually, it will impact battery performance.</p>
---	--

Battery part lists

NO.	Pictures	Item	Qty'
1		Storage Battery	1
2		Mounted bracket	1

3		Right mounted bracketed	1
4		Left mounted bracketed	1
5		Expansion bolts	4
6		Screw	4

Installation tool and safety gear

NO.	Pictures	Tool(safety gear)
1		Hammer
2		Drill
3		Wrench
4		Hex Wrench
5		Level ruler
6		Marker pen

7		Insulated gloves
8		Safety goggles
9		Safety shoes

### Storage Battery Installation

1. Put level meter on the wall and then to mark two drilling positions. The position distance is  $484\pm 1$ mm.

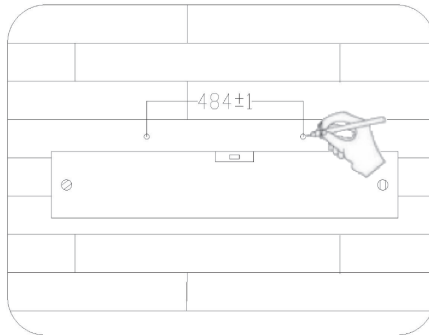

2. Drill holes in the marked positions with  $\phi 6$ mm drill bit. The depth is 38mm.

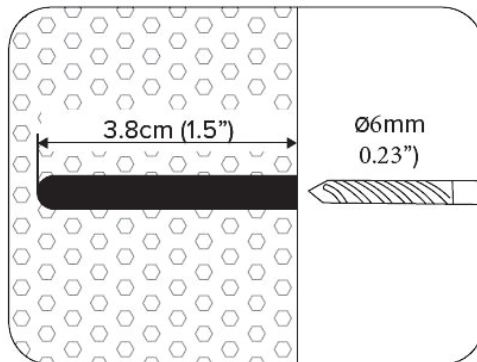

3. Insert the expansion bolts into the hole by hammer.

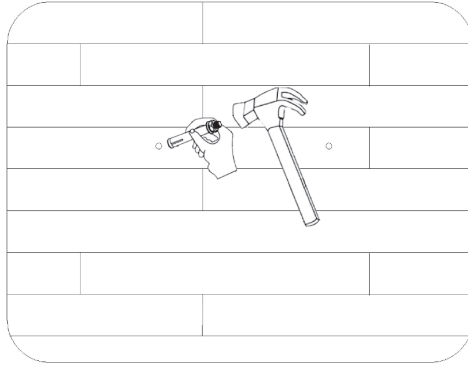

4. Tighten M5 screw through right/left mounted bracket into the battery.

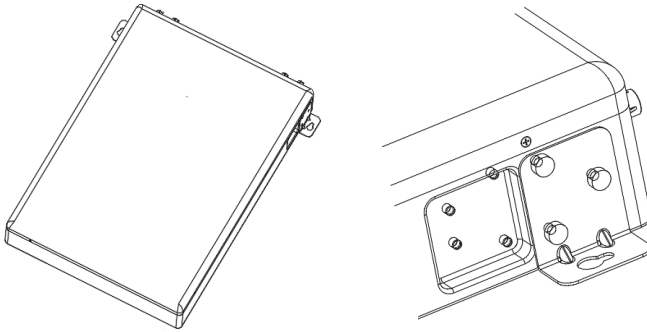

5. Hang the battery onto the wall and tighten with nuts.

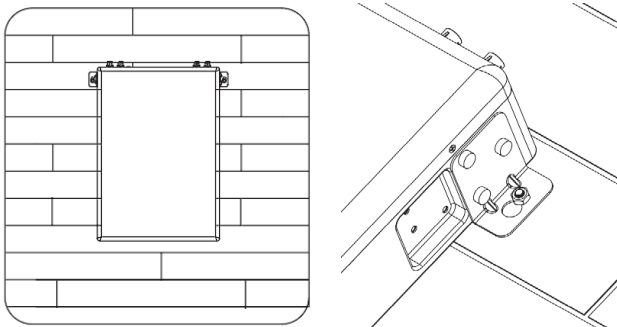

6. Place the mounted bracket to follow the installation position onto the battery and mark the position hole on the wall.



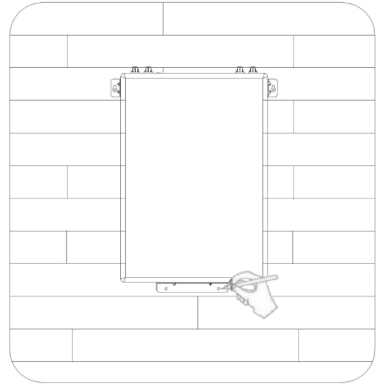
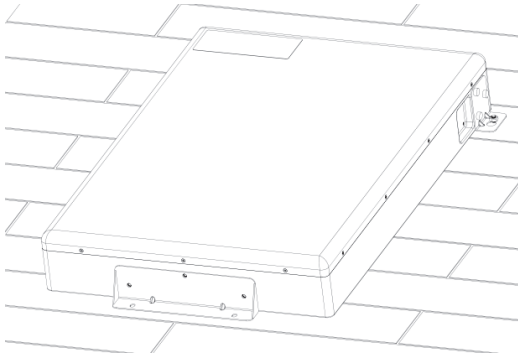

7. Take off the mounted bracket. Drill holes in the marked position and the depth is 38mm.

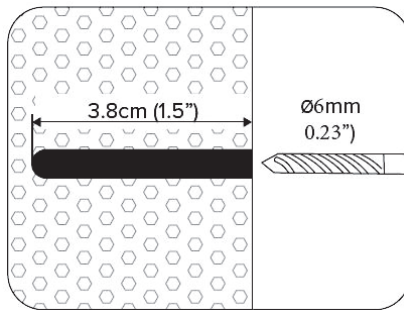

8. Insert the expansion bolts into the hole by hammer.

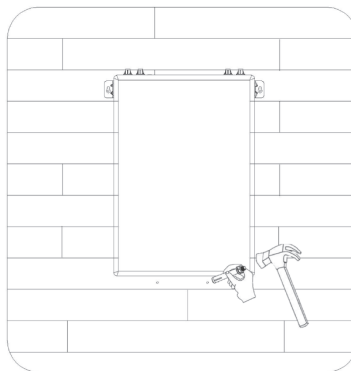

9. Tighten the screw through mounted bracket into the battery.

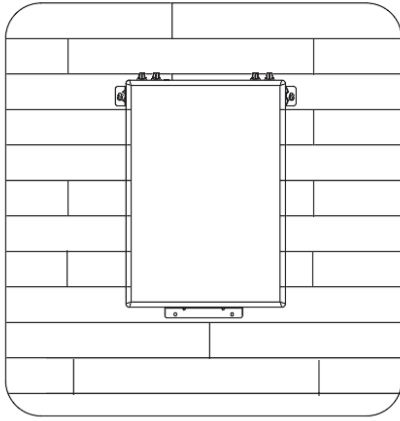

**Storage Battery Installation - Battery Connection in Parallel**

Power cable & communication cable for battery module package ( Wall - mounted )

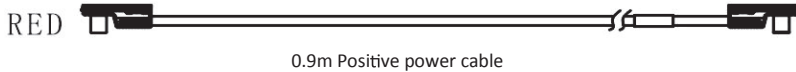
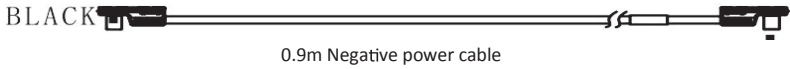

Power cable & communication cable for connection between battery and storage inverter ( Wall - mounted )

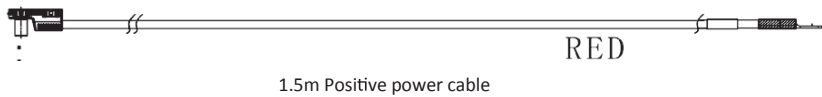
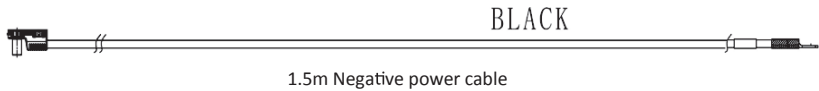

1. After battery installation on the wall, to connect the power / commutation cable between battery and storage inverter.

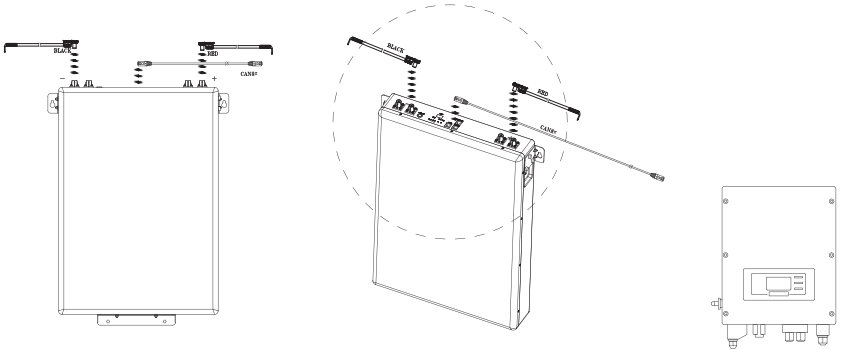

2. To use power cable for connection of twobatteries.

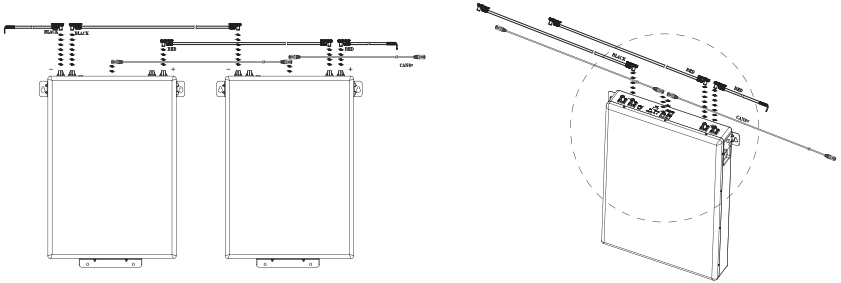

3. To use power cable for connection of four batteries.

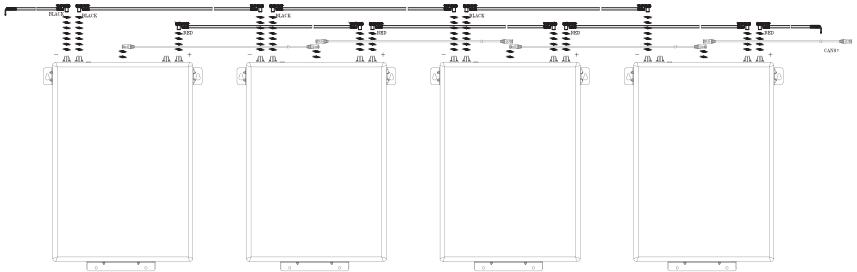

4. Make sure : the dial code is correct, the positive and negative terminals of the battery are connected correctly, CAN communication cable is correct, Press each battery switch button.

5. If any help is needed,please contact ZANTIA technical support.

Inspired by *Comfort!*

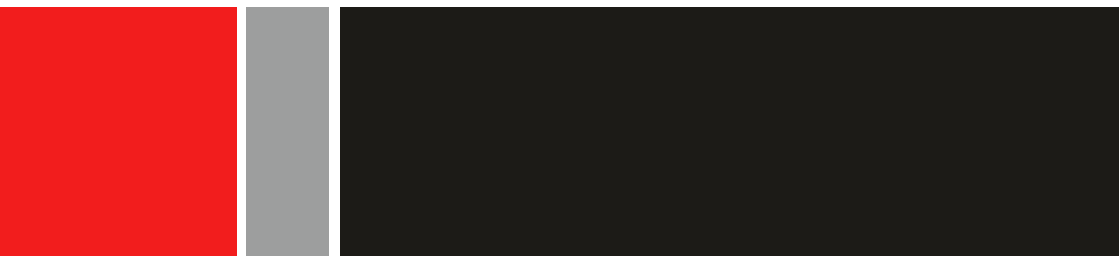

[www.zantia.com](http://www.zantia.com)